

M18 THROUGH BEAM OPTICAL SENSOR / SWITCH

OPERATIONAL DATA:

- | | |
|---------------------|-------------------------------|
| 1. FUNCTION | THROUGH BEAM TYPE |
| 2. SENSING RANGE | 0.....5M Adjustable from rear |
| 3. OUTPUT | PNP / NPN NO OR NC |
| 4. INDICATION | LED FOR OUTPUT ON |
| 5. AMB. TEMP. RANGE | 0 °C. TO 70 °C. |

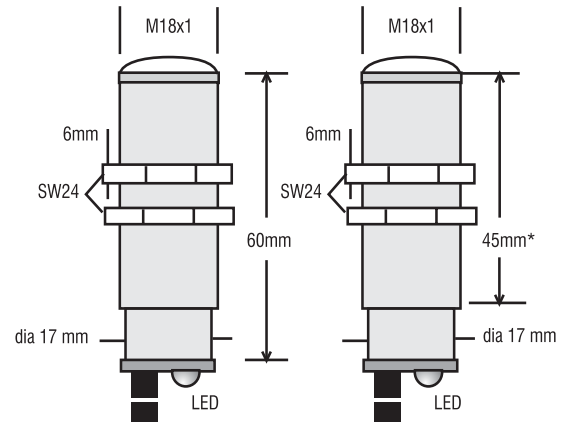

ELECTRICAL DATA:

- | | |
|----------------------------|---|
| 6. OPERATING VOLTAGE | 10 V TO 24 VDC |
| 7. CURRENT CONSUMPTION | EMITTER < 15mA
RECEIVER < 40mA |
| 8. DROPOUT VOLTAGE | <2V @ max load current |
| 9. SWITCHING FREQUENCY | 100 Hz |
| 10. LOAD CURRENT (MAXIMUM) | 200mA |

ORDERING CODE: TYPE

- | | |
|-------------------|---------------------------|
| PSPBB18PATXCB02RS | PNP/200mA/THRU BEAM/NO-NC |
| PSPBB18NATXCB02RS | NPN/200mA/THRU BEAM/NO-NC |

- | | |
|----------------|---------------------|
| NO = Output On | Without Obstruction |
| NC = Output On | With Obstruction |

MECHANICAL DATA:

- | | |
|-----------------|---|
| 11. HOUSING | M18 X 1mm PAIR OF THREADED BRASS BARRELS Ni-CHROME PLATED |
| 12. MOUNTING | Dia 18 mm THRU HOLE FIXING BY M18 x1 mm TAPPED PAIR OF NUTS |
| 13. TERMINATION | Cu CABLE PVC INSULATED 3X0.34 Sq.mm. |

*** Please contact factory for different barrel lengths.**

PROTECTION FEATURES:

- | | |
|-----------------------|----------------------------------|
| 14. ENVIRONMENTAL | IP67 |
| 15. POLARITY REVERSAL | YES |
| 16. OUTPUT | AGAINST INDEFINITE SHORT CIRCUIT |

CONNECTION DETAILS:

	RECEIVER		EMITTER
	NO	NC	
BROWN	+V	0 V	+V
BLACK	OUTPUT	OUTPUT	NU
BLUE	0 V	+V	-Ve

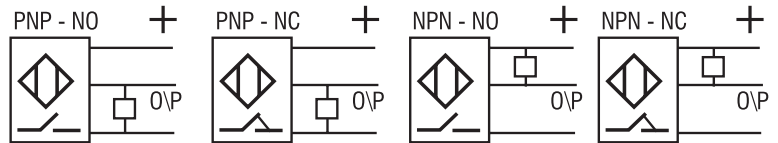
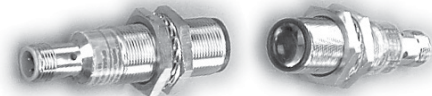

Specifications are subject to change without notice.