

CONVEYER BELT INITIATOR 11 x 35 FOR SCHLAFHORTS WINDING MACHINE **4mm**
NON-FLUSH

OPERATIONAL DATA:

- | | |
|--|-----------------------|
| 1. MOUNTING IN METAL | NON-FLUSH |
| 2. SWITCHING DISTANCE WITH Fe-ST37 PLATE
SIZE-12mm X 12mm X 1mm | 4mm |
| 3. HYSTERESIS | 3% TO 15% |
| 4. REPEATABILITY | 0.01mm |
| 5. TEMPERATURE DRIFT | =>10% |
| 6. AMB. TEMP.RANGE | 0 DEG.C. TO 70 DEG.C. |

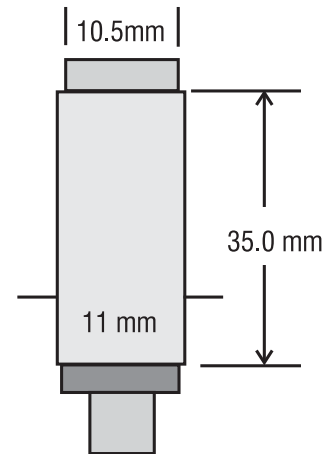

ELECTRICAL DATA:

- | | |
|-------------------------|------------------------|
| 7. OPERATING VOLTAGE | 10 V TO 30 VDC |
| 8. CURRENT CONSUMPTION | <20mA |
| 9. DROPOUT VOLTAGE | <1V @ max load current |
| 10. SWITCHING FREQUENCY | 1 KHz |
| 11. LOAD CURRENT (max) | 200mA |

ORDERING CODE

PSI11X35PNT

Eqv. to SCHLAFHORTS PART NO:

8.85 910014 #

MECHANICAL DATA:

- | | |
|-----------------|---|
| 12. HOUSING | 11 mm PLAIN BRASS BARREL
BARREL NI-CHROME PLATED |
| 13. MOUNTING | Dia 11 mm THRU HOLE FIXING |
| 14. TERMINATION | Cu CABLE PVC INSULATED
3X0.34 Sq.mm. |



PROTECTION FEATURES:

- | | |
|-----------------------|----------------------------------|
| 15. ENVIRONMENTAL | IP67 |
| 16. POLARITY REVERSAL | YES |
| 17. OUTPUT | AGAINST INDEFINITE SHORT CIRCUIT |

CONNECTION DETAILS:

- | | |
|-------|--------|
| BROWN | +V |
| BLACK | OUTPUT |
| BLUE | 0V |

Recommended for the application subject to manufacturer's change time to time.

**Please contact factory for different barrel lengths.

Specifications are subject to change without notice.

